

# MLCC



## 一、Part Number System

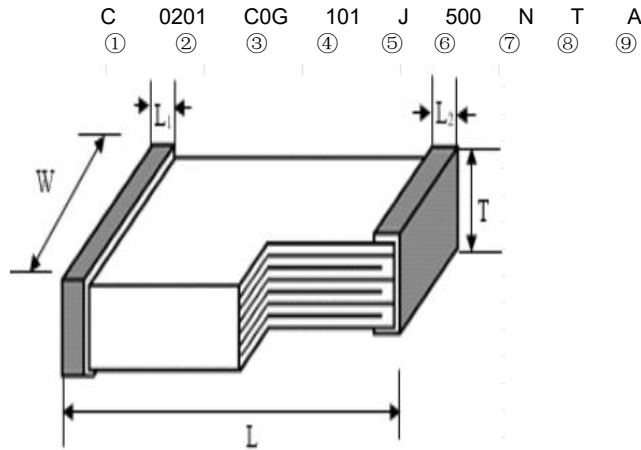

Figure 1 Product Outline Drawing

### ①.Application category or feature

- C-Multilayer Ceramic Chip Capacitors for General Purpose
- U-High-Q Multilayer Ceramic Chip Capacitors
- P-High-power&High-Q Multilayer Ceramic Chip Capacitors
- B-Industrial Grade Multilayer Ceramic Chip Capacitors
- A-Automotive Grade Multilayer Ceramic Chip Capacitors
- Q-Automotive Grade High-Q Multilayer Ceramic Chip Capacitors
- E-Automotive grade MLCC for Powertrain& Safety

### ②.Size Code

Size Code	GB/IEC/EIA	JIS	L/mm	W/mm
A8A4	08004	0201	0.25	0.125
0105	01005	0402	0.4	0.2
0201	0201	0603	0.6	0.3
0402	0402	1005	1	0.5
0603	0603	1608	1.6	0.8
0805	0805	2012	2	1.25
1206	1206	3216	3.2	1.6
1210	1210	3225	3.2	2.5

### ③.Medium characteristics or Temperature characteristics

Applicati on Character istics Code	Temperature Characteristi cs	STD	Operating Temperature	Temp. Coeff Or Cap. Change	Reference Temperature	Characteristics temperature
HQC/C0G	C0G	EIA	-55℃ ~ +125℃	0±30ppm/℃	25℃	25℃ ~ +125℃
X5R	X5R	EIA	-55℃ ~ +85℃	±15%	25℃	-55℃ ~ +85℃
X6S	X6S	EIA	-55℃ ~ +105℃	±22%	25℃	-55℃ ~ +105℃
X6T	X6T	EIA	-55℃ ~ +105℃	22%/-33%	25℃	-55℃ ~ +105℃
X7R	X7R	EIA	-55℃ ~ +125℃	±15%	25℃	-55℃ ~ +125℃
X7S	X7S	EIA	-55℃ ~ +125℃	±22%	25℃	-55℃ ~ +125℃
X7T	X7T	EIA	-55℃ ~ +125℃	22%/-33%	25℃	-55℃ ~ +125℃
X8G	X8G	EIA	-55℃ ~ +150℃	0±30ppm/℃	25℃	25℃ ~ +150℃

**④. Capacitance Code**

Expressed by three-digit alphanumerics. The unit is pF. The first and second figures are significant digits, and the third figure expresses the number of zeros which follow the two numbers. When the capacitance is lower than 10pF, "R" is applied, standing for decimal point.

Examples:

104=100000pF; 223=22000pF

4R7=4.7pF; 0R5=0.5pF; 5R0=5.0pF; R75=0.75pF.

**⑤. Tolerance Code**

Code	Tolerance	Code	Tolerance	Code	Tolerance
A	±0.05pF	G	±2%	N	±30%
B	±0.1pF	J	±5%	X	±40%
C	±0.25pF	K	±10%	S	50%/-20%
D	±0.5pF	L	±15%	Z	80%/-20%
F	±1%	M	±20%	Y	150%/-20%

**⑥. Rate Voltage Code**

The first two digits of the rated voltage code are valid digits, and the third figure expresses the number of zeros which follow the two numbers, where the decimal point is represented by the letter R.

Code	Voltage	Code	Voltage	Code	Voltage
2R5	2.5V	160	16V	101	100V
4R0	4.0V	250	25V	201	200V
6R3	6.3V	350	35V	501	500V
100	10V	500	50V	102	1000V

**⑦. Termination**

N represent the "Cu/Ni/Sn" Structure, C represent the All plating copper termination.

**⑧. Packaging Code**

Size Code	GB/IEC/EIA	Packing code	Disc Size	Carrier Tap Type	QTY (Kpcs)
/	/	B	/	/	Bulk
A8A4	008004	P	7"	Plastic	50
0105	01005	T	7"	Paper	20
	01005	P	7"	Plastic	40
0201	0201	H	7"	Paper	10
		T	7"	Paper	15
		J	13"	Paper	50
		L	7"	Paper	30
		D	13"	Paper	100
0402	0402	T	7"	Paper	10
		L	7"	Paper	20
		J	13"	Paper	50
		D	13"	Paper	100
0603	0603	R	7"	Plastic	3
		M	7"	Paper	10
		T	7"	Paper	4
		Q	7"	Plastic	4
		A	13"	Paper	15
0805	0805	P	7"	Plastic	2
		R	7"	Plastic	3
		T	7"	Paper	4
		O	13"	Plastic	10
1206	1206	R	7"	Plastic	3
		P	7"	Plastic	2
		T	7"	Paper	4
		E	13"	Plastic	8
1210	1210	P	7"	Plastic	2
		Z	7"	Plastic	1
		S	7"	Plastic	0.5
		F	7"	Plastic	1.5

⑨. Thickness Code

Product schematic diagram

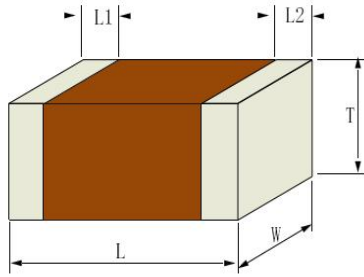

Size	Length(L)/m	Width(W)/mm	L1, L2/mm	Thickness(T)/mm	Thickness Code
A8A4 (008004)	0.25±0.013	0.125±0.013	0.05~0.10	0.125±0.013	1
0105 (01005)	0.40±0.02	0.20±0.02	0.07~0.13	0.20±0.02	Z
0201	0.60±0.03	0.30±0.03	0.10~0.20	0.30±0.03	A
0201	0.60+0.05/-	0.30+0.05/-0.03	0.10~0.20	0.30+0.05/-0.03	J
0201	0.6±0.09	0.3±0.09	0.10~0.20	0.3±0.09	F
0201	0.60+0.1/-	0.30+0.1/-0.03	0.10~0.20	0.30+0.1/-0.03	X
0201	0.6±0.09	0.3±0.09	0.10~0.20	0.5±0.05	B
0402	1.00±0.05	0.50±0.05	0.15~0.35	0.50±0.05	B
0402	1.00+0.15/-	0.50+0.15/-0.05	0.15~0.35	0.50+0.15/-0.05	N
0402	1.00+0.20/-	0.50+0.20/-0.05	0.15~0.35	0.50+0.20/-0.05	C
0402	1.00+0.30/-	0.50+0.30/-0.05	0.15~0.35	0.30±0.03	A
0402	1.00+0.20/-	0.50+0.20/-0.05	0.15~0.35	0.50+0.03/-0.05	U
0603	1.60±0.10	0.80±0.10	0.20~0.50	0.80±0.10	D
0603	1.60+0.20/-	0.80+0.20/-0.1	0.20~0.50	0.45±0.05	S
0603	1.60±0.10	0.80±0.10	0.20~0.50	0.70±0.10	U
0603	1.60+0.20/-	0.80+0.20/-0.1	0.20~0.50	0.80+0.20/-0.1	K
0603	1.60±0.25	0.80±0.25	0.20~0.50	0.80±0.25	4
0603	1.60+0.30/-	0.80+0.30/-0.1	0.20~0.50	0.80+0.30/0	W
0805	2.00±0.10	1.25±0.10	0.20~0.70	0.60±0.10	C
0805	2.00±0.20	1.25±0.20	0.20~0.70	0.85±0.15	K
0805	2.00±0.20	1.25±0.20	0.20~0.70	0.85+0.15/-0.35	Y
0805	2.0±0.2	1.25±0.2	0.20~0.70	1.25±0.20	H
0805	2.00+0.25/-	1.25+0.25/-0.15	0.20~0.70	1.25+0.25/-0.15	5
0805	2.00±0.20	1.25±0.20	0.20~0.70	0.85±0.10	E
0805	2.00±0.10	1.25±0.10	0.20~0.70	1.90±0.20	M
1206	3.20±0.15	1.60±0.15	0.30~0.80	0.85±0.10	E
1206	3.20±0.15	1.6±0.15	0.30~0.80	0.85+0.15/-0.35	Y
1206	3.20±0.20	1.6±0.20	0.30~0.80	1.15±0.15	O
1206	3.20±0.20	1.6±0.20	0.30~0.80	1.60±0.20	L
1206	3.20±0.30	1.60±0.30	0.30~0.80	1.60±0.30	P
1210	3.20±0.20	2.5±0.20	0.30~0.90	1.60±0.20	L
1210	3.20±0.20	2.5±0.20	0.30~0.90	2.00±0.20	Q
1210	3.20±0.30	2.5±0.20	0.30~0.90	2.50±0.20	R
1210	3.20±0.40	2.5±0.30	0.30~0.90	2.50±0.30	3

**General Purpose MLCC Capacitors (C Series)**

**Application Field**

Mobile phone and peripheral products, PC and peripheral products, network communication products, household appliances and other general products

**Characteristics**

- (1) A complete range of products to meet the needs of smaller size and higher capacity
- (2) Used for filtering, energy storage, coupling and other functions of general electronic circuits



TC	尺寸 Size	电压 Rated Volltag	容值Capacitance														范围				
			101	102	472	103	223	333	473	104	224	474	105	225	475	106	226	476	107	Cap Range	
X5R	008004	10V	■	■															100pF~680pF		
		6.3V			■	■	■	■	■	■	■	■	■	■	■	■	■	■	■	1nF~22nF	
		4V			■	■	■	■	■	■	■	■	■	■	■	■	■	■	■	1nF~22nF	
	01005	16V	■	■	■	■	■	■	■	■	■	■	■	■	■	■	■	■	■	51pF~10nF	
		10V	■	■	■	■	■	■	■	■	■	■	■	■	■	■	■	■	■	51pF~100nF	
	0201	6.3V			■	■	■	■	■	■	■	■	■	■	■	■	■	■	■	150pF~470nF	
		50V	■	■	■	■	■	■	■	■	■	■	■	■	■	■	■	■	■	100pF~15nF	
		35V					■	■	■	■	■	■	■	■	■	■	■	■	■	18nF~100nF	
		25V	■	■	■	■	■	■	■	■	■	■	■	■	■	■	■	■	■	100pF~470nF	
		16V			■	■	■	■	■	■	■	■	■	■	■	■	■	■	■	150pF~1μF	
		10V			■	■	■	■	■	■	■	■	■	■	■	■	■	■	■	150pF~2.2μF	
		6.3V			■	■	■	■	■	■	■	■	■	■	■	■	■	■	■	150pF~4.7μF	
		4V											■	■	■	■	■	■	■	470nF~4.7μF	
		0402	50V	■	■	■	■	■	■	■	■	■	■	■	■	■	■	■	■	■	100pF~470nF
			35V							■	■	■	■	■	■	■	■	■	■	■	56nF~100nF/1μF
			25V	■	■	■	■	■	■	■	■	■	■	■	■	■	■	■	■	■	120pF~4.7μF
			16V	■	■	■	■	■	■	■	■	■	■	■	■	■	■	■	■	■	120pF~4.7μF
	10V		■	■	■	■	■	■	■	■	■	■	■	■	■	■	■	■	■	120pF~10μF	
	6.3V		■	■	■	■	■	■	■	■	■	■	■	■	■	■	■	■	■	120pF~22μF	
	0603	50V			■	■	■	■	■	■	■	■	■	■	■	■	■	■	■	220pF~2.2μF	
		35V										■	■	■	■	■	■	■	■	680nF~10μF	
		25V										■	■	■	■	■	■	■	■	680nF~10μF	
		16V										■	■	■	■	■	■	■	■	680nF~22μF	
		10V										■	■	■	■	■	■	■	■	680nF~22μF	
6.3V												■	■	■	■	■	■	■	2.2μF~47μF		
0805	4V															■	■	■	10μF~47μF		
	50V			■	■	■	■	■	■	■	■	■	■	■	■	■	■	■	220pF~10μF		
	35V										■	■	■	■	■	■	■	■	680nF~4.7μF		
	25V										■	■	■	■	■	■	■	■	680nF~22μF		
	16V										■	■	■	■	■	■	■	■	1μF~22μF		
	10V											■	■	■	■	■	■	■	2.2μF~47μF		
	6.3V											■	■	■	■	■	■	2.2μF~100μF			

TC	尺寸 Size	电压 Rated Volltag	容值Capacitance														范围			
			101	102	472	103	223	333	473	104	224	474	105	225	475	106	226	476	107	Cap Range
X5R	1206	50V										■	■	■	■	■	■	■	680nF~10μF	
		35V											■	■	■	■	■	■	2.2μF~4.7μF	
		25V												■	■	■	■	■	■	4.7μF~22μF
		16V													■	■	■	■	■	4.7μF~47μF
		10V														■	■	■	■	22μF~100μF
		6.3V															■	■	■	22μF~100μF
	1210	25V											■	■	■	■	■	■	■	680nF~10μF
		16V														■	■	■	■	4.7μF~47μF
		10V															■	■	■	680nF~22μF





**Product range**

TC	尺寸 Size	电压 Rated Voltag	容值Capacitance																范围	
			0R1	0R2	0R5	R75	1R0	1R5	2R2	3R3	4R7	6R8	100	150	220	330	470	680	101	Cap Range
C0G	01005	50V																		0.2pF~22pF
		25V																		0.2pF~22pF
		16V																		0.2pF~22pF
	0201	50V																		0.1pF~33pF
		25V																		0.1pF~33pF
	0402	50V																		0.1pF~33pF
25V																			0.1pF~33pF	

**High-Q MLCC Capacitors (U Series)**

**Application Field**

PA and related modules, WiFi module, 5G base station and other RF Applications

**Characteristics**

(1) High Rated Voltage

The maximum rated voltage can reach 100Vdc

(2) Compared with Ni internal electrode, Cu internal electrode shows more excellent high frequency characteristics

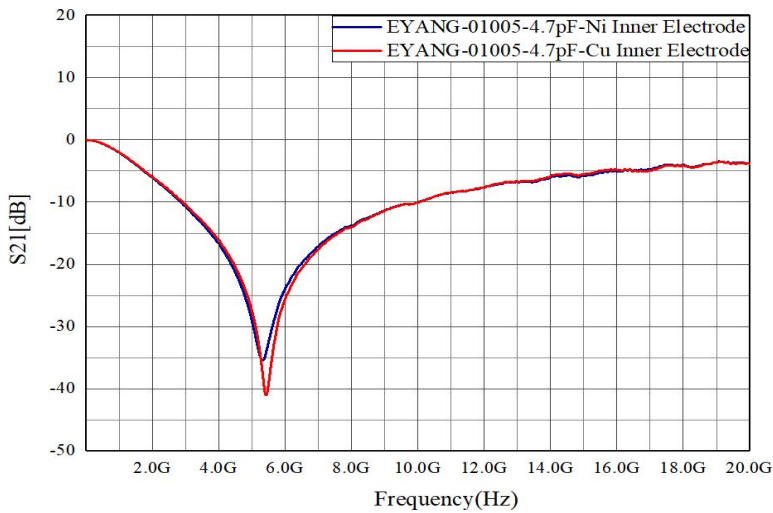

(3) High reliability

The series meet the requirements of various applications from consumer applications to industrial applications

**Product range**

TC	尺寸 Size	电压 Rated Voltag	容值Capacitance																范围	
			0R1	0R2	0R5	R75	1R0	1R5	2R2	3R3	4R7	6R8	100	150	220	330	470	680	101	Cap Range
C0G	01005	25V																		0.2pF~22pF
		16V																		0.2pF~22pF
	0201	100V																		0.2pF~33pF
		50V																		0.2pF~33pF
	0402	25V																		0.2pF~33pF
		100V																		0.2pF~33pF
	0603	50V																		0.1pF~47pF
		25V																		0.1pF~47pF
	0603	50V																		0.1pF~100pF
25V																			0.1pF~100pF	

**High-power&High-Q MLCC Capacitors (P Series)**

**Application Field**

Mobile communication equipment base station and related modules

**Characteristics**

(1) High operating temperature

The maximum working temperature of the series is 125°C~150°C

















X5R	0201	25V	[Capacitance Range]																0.15nF-100nF		
		16V	[Capacitance Range]																10nF~470nF		
		10V	[Capacitance Range]																10nF~1μF		
		6.3V	[Capacitance Range]																10nF~1μF		
		4V	[Capacitance Range]																1μF		
	0402	25V	[Capacitance Range]																33nF~470nF		
		16V	[Capacitance Range]																220nF~2.2μF		
		10V	[Capacitance Range]																1μF/2.2μF/4.7μF		
		6.3V	[Capacitance Range]																1μF~4.7μF		
		4V	[Capacitance Range]																4.7μF		
	0603	50V	[Capacitance Range]																1μF		
		35V	[Capacitance Range]																2.2μF		
		25V	[Capacitance Range]																2.2μF~4.7μF		
		16V	[Capacitance Range]																2.2μF~10μF		
		10V	[Capacitance Range]																2.2μF~10μF		
	0805	25V	[Capacitance Range]																1.0μF-10μF		
		16V	[Capacitance Range]																2.2μF-10μF		
		10V	[Capacitance Range]																3.3μF-22μF		
		6.3V	[Capacitance Range]																3.3μF-22μF		
	1206	50V	[Capacitance Range]																4.7μF		
35V		[Capacitance Range]																1μF~10μF			
25V		[Capacitance Range]																1μF~10μF			
16V		[Capacitance Range]																1.5μF~22μF			
10V		[Capacitance Range]																10μF~47μF			
6.3V		[Capacitance Range]																10μF~47μF			
1210	50V	[Capacitance Range]																3.3μF~4.7μ			
	25V	[Capacitance Range]																3.3μF~22μF			
	16V	[Capacitance Range]																10μF~22μF			
TC	尺寸 Size	电压 Rated Voltage	容值Capacitance																范围 Cap Range		
X5R	1210	10V	151	221	103	333	683	104	224	334	474	105	155	225	335	475	106	226	476	107	22μF
		6.3V																			22μF~100μF

### Automotive Grade High-Q MLCC Capacitors (Q-Series)

#### Application Field

The RF circuit of vehicle communication system require high Q and low ESR.

#### Characteristics

- (1) High temperature withstanding, high reliability, long operational life, certified with AEC-Q200
- (2) Cu inner electrode shows high Q value and excellent high frequency characteristics







**Carrier tape size specification of 0603 or above**

**Size (unit: mm)**

Size specification	0603	0805	1206	1210
Product thickness code	-	-	-	-
A(Width of square hole)	1.00±0.20	1.60±0.20	1.88±0.20	2.72±0.2
B(Length of square hole)	1.80±0.20	2.40±0.20	3.50±0.20	3.50±0.2
F(Central X-axis distance of round hole and square hole)	3.50±0.05	3.50±0.05	3.50±0.05	3.50±0.0
P(Square hole spacing)	4.00±0.10	4.00±0.10	4.00±0.10	4.00±0.1
E(Round hole edge distance)	1.75±0.1	1.75±0.1	1.75±0.1	1.75±0.1
D0(Round hole diameter)	1.55±0.05	1.55±0.05	1.55±0.05	1.55±0.0
P2(Central Y-axis distance of round hole and square hole)	2.00±0.05	2.00±0.05	2.00±0.05	2.00±0.0
W(Carrier tape width)	8.00±0.20	8.00±0.20	8.00±0.20	8.00±0.2
P0(Central distance of round hole)	4.00±0.1	4.00±0.1	4.00±0.1	4.00±0.1
Packaging code	-	-	-	-

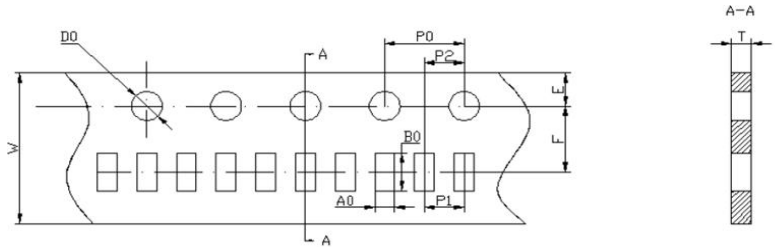

Applicable to size specification of 0402

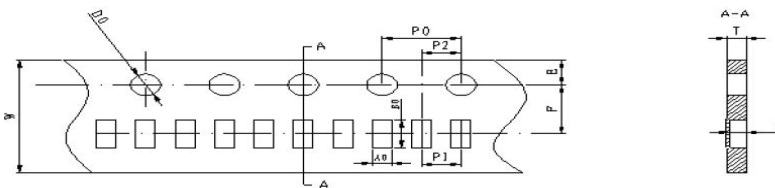

Applicable to size specification of 0201/0105

**Applicable to carrier tape size specification of 0402 or lower**

**Size (unit: mm)**

Size specification	A8A4	0105	0105	0201	0201	0201
Product thickness code	1	Z	Z	A	J	X/F
A0(Width of square hole)	0.145±0.007	0.24±0.02	0.24±0.02	0.38±0.02	0.44±0.02	0.46±0.02
B0(Length of square hole)	0.270±0.007	0.45±0.02	0.45±0.02	0.68±0.02	0.74±0.02	0.76±0.02
F(Central X-axis distance of round hole and square hole)	1.80±0.05	3.50±0.05	1.80±0.05	3.50±0.05	3.50±0.05	3.50±0.05
P1(Square hole spacing)	1.00±0.05	2.00±0.05	1.00±0.05	2.00±0.05	2.00±0.05	2.00±0.05
E(Round hole edge distance)	0.90±0.1	1.75±0.1	0.90±0.1	1.75±0.1	1.75±0.1	1.75±0.1
D0(Round hole diameter)	0.80±0.05	1.55±0.05	0.80±0.05	1.55±0.05	1.55±0.05	1.55±0.05
P2(Central Y-axis distance of round hole and square hole)	1.00±0.05	2.00±0.05	1.00±0.05	2.00±0.05	2.00±0.05	2.00±0.05
K(Depth of square hole)	0.145±0.007	0.24±0.02	0.24±0.02	0.36±0.02	0.40±0.02	0.44±0.02
W(Width of carrier tape)	4.00±0.10	8.00±0.10	4.00±0.10	8.00±0.10	8.00±0.10	8.00±0.10
P0(Central distance of round hole)	2.00±0.1	4.00±0.1	2.00±0.1	4.00±0.1	4.00±0.1	4.00±0.1
Packaging code	P	T	P	H/J/T	H/J/T	H/J/T

Size specification	0201	0201	0201	0201	0402	0402
Product thickness code	A	J	X	B	-	B
A0(Width of square hole)	0.38±0.02	0.44±0.02	0.46±0.02	0.46±0.02	0.70±0.10	0.70±0.10
B0(Length of square hole)	0.68±0.02	0.74±0.02	0.76±0.02	0.76±0.02	1.20±0.10	1.20±0.10
F(Central X-axis distance of round hole and square hole)	3.50±0.05	3.50±0.05	3.50±0.05	3.50±0.05	3.50±0.05	3.50±0.05
P1(Square hole spacing)	1.00±0.05	1.00±0.05	1.00±0.05	2.00±0.05	2.00±0.05	1.00±0.05
E(Round hole edge distance)	1.75±0.1	1.75±0.1	1.75±0.1	1.75±0.1	1.55±0.1	1.55±0.1
D0(Round hole diameter)	1.55±0.05	1.55±0.05	1.55±0.05	1.55±0.05	1.55±0.05	1.55±0.05
P2(Central Y-axis distance of round hole and square hole)	1.00±0.05	1.00±0.05	1.00±0.05	2.00±0.05	2.00±0.05	1.00±0.05
K(Depth of square hole)	0.36±0.02	0.40±0.02	0.40±0.02	0.60±0.05	/	/
W(Width of carrier tape)	8.00±0.10	8.00±0.10	8.00±0.10	8.00±0.10	8.00±0.10	8.00±0.10
P0(Central distance of round hole)	4.00±0.1	4.00±0.1	4.00±0.1	4.00±0.1	4.00±0.1	4.00±0.1
Packaging code	L/D	L/D	L/D	H	-	L/D

### 1.3 Disc Size

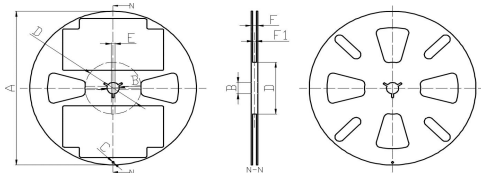

Reel is suitable for 4mm carrier tape width.

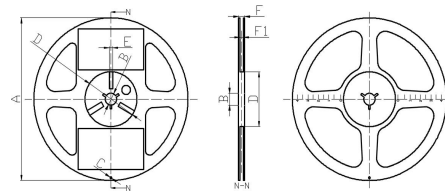

Reel is suitable for 8mm carrier tape width.

Disc size (inch)	Width(mm)	A/mm	B/mm	C/mm	D/mm	E/mm	F/mm	F1/mm	Dimension
7"	8.00±0.10	Φ178±2.0	Φ13±1.0	Φ4±0.5	Φ60±2.0	4±1.0	11.5±1.0	10±2.0	Standard
13"	8.00±0.10	Φ330±2.0	Φ13±1.0	Φ4±0.5	Φ108±2.0	4±1.0	13.5±2.0	10±2.0	Standard
7"	4.00±0.10	Φ178±2.0	Φ13±1.0	Φ4±0.5	Φ60±2.0	3.5±0.5	7.3±0.5	4.5±1.0	01005/AA A4

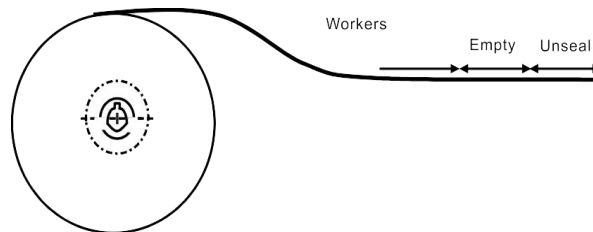

### 1.4 Carrier Specification Trailer

Packaging	Minimum length of reserved spaces		
	Trailer	Empty	Unseal
Carrier Tape	60 mm	200mm	160mm

### 1.5 Carrier Tape Performance

#### 1.5.1 Strength of Carrier Tape and Upper Cover Tape

- Carrier Tape: the carrier tape shall endure pressure of 1.02kg in the straight state.
- Upper Cover Tape: the upper cover tape shall endure pressure of 1.02kg.

### **1.5.2 Stripping Strength of Upper Cover Tape**

Unless otherwise specified, the stripping strength shall be within 10.2-71.4 gf when the upper cover tape is stripped from the carrier tape at a speed of 300mm/min at an angle of 0-15° (as shown below).

### **2 Transportation**

The packaged product is suitable for transportation with modern vehicle, but shall be prevented from rain and acid-alkali corrosion in the transportation process, and violent throwing or squeezing.

### **3 Storage**

3.1 Storage condition: temperature: 5°C~40°C relative humidity: lower than RH70%. The property of the product may be affected by storage conditions, please use in time after shipment.

The packaging material may be deteriorated when stored under high temperature and damp condition and/or in long-term storage.

Please check the packaging, mountings, etc. before use after 6 months of shipment.

In addition, electrode oxidation may be caused. Check weldability before use after 1 year of shipment.

3.2 Corrosive gas can react with terminal (external) electrode or lead of capacitor, resulting in poor weldability. Please do not store the capacitor in environment of corrosive gas (e.g. hydrogen sulfide, sulfur dioxide, chlorine, ammonia gas, etc.)

### **Notes**

#### **Operating Temperature**

a. Do not use capacitor above the maximum allowable operating temperature.

b. Surface temperature including self heating should be below maximum operating temperature.

#### **Operating Voltage**

a. The operating voltage of the capacitor must be lower than its rated voltage.